

FIPS Module

Security Policy

Disclaimer

Honeywell International Inc. ("HII") reserves the right to make changes in specifications and other information contained in this document without prior notice, and the reader should in all cases consult HII to determine whether any such changes have been made. The information in this publication does not represent a commitment on the part of HII.

HII shall not be liable for technical or editorial errors or omissions contained herein; nor for incidental or consequential damages resulting from the furnishing, performance, or use of this material.

This document contains proprietary information that is protected by copyright. All rights are reserved. No part of this document may be photocopied, reproduced, or translated into another language without the prior written consent of HII.

© 2011 Honeywell International Inc. All rights reserved.

Web Address: www.honeywellaidc.com

This software contains trade secrets, confidential information, and other intellectual property of Certicom Corp. and its licensors. This software cannot be used, reproduced, or distributed in whole or in part by any means without the explicit prior consent of Certicom Corp. Such consent must arise from a separate license agreement from Certicom or its licensees, as appropriate.

Certicom, Certicom AMS, ACC, Asset Control Core, Certicom Bar Code Authentication Agent, Certicom ECC Core, Certicom Security Architecture, Certicom Trusted Infrastructure, Certicom CodeSign, Certicom KeyInject, ChipActivate, DieMax, Security Builder, Security Builder API, Security Builder API for .NET, Security Builder BSP, Security Builder Crypto, Security Builder ETS, Security Builder GSE, Security Builder IPsec, Security Builder MCE, Security Builder NSE, Security Builder PKI, Security Builder SSL and SysActivate are trademarks or registered trademarks of Certicom Corp. All other companies and products listed herein are trademarks or registered trademarks of their respective holders.

BlackBerry®, RIM®, Research In Motion®, and related trademarks are owned by Research In Motion Limited. Used under license.

Certicom Corp. has intellectual property rights relating to technology embodied in the product that is described in this document. In particular, and without limitation, these intellectual property rights may include one or more of the U.S. and non-U.S. patents listed at www.certicom.com/patents and one or more additional patents or pending patent applications in the U.S. and in other countries. Information is subject to change.



Table of Contents

Chapter 1 - Introduction

Overview	1-1
Purpose	1-1
References	1-1
Change Notes	1-1

Chapter 2 - Cryptographic Module Specification

Physical Specifications	2-1
Version 4.0 B Hardware	2-1
Version 4.0 S Hardware	2-2
Firmware Specifications	2-4
Version 4.0 B Firmware	2-4
Version 4.0 S Firmware	2-4

Chapter 3 - Cryptographic Module Ports and Interfaces

Version 4.0 B Ports and Interfaces	3-1
Version 4.0 S Ports and Interfaces	3-1

Chapter 4 - Roles, Services, and Authentication

Roles	4-1
Services	4-1
Operator Authentication	4-2

Chapter 5 - Finite State Model

Chapter 6 - Physical Security

Chapter 7 - Operational Environment

Chapter 8 - Cryptographic Key Management

Key Generation	8-1
Key Establishment	8-1
Key Entry and Output	8-1
Key Storage	8-1
Zeroization of Keys	8-1

Chapter 9 - Self-Tests

Power-up Tests	9-1
Tests upon Power-up	9-1
On-Demand Self-Tests	9-1
Conditional Tests	9-1
Failure of Self-Tests	9-1

Chapter 10 - Design Assurance

Configuration Management	10-1
Delivery and Operation	10-1
Development	10-1
Guidance Documents	10-1

Chapter 11 - Mitigation of Other Attacks

Mitigation of Other Attacks	11-1
Attack on Biased Private Key of DSA	11-1

Chapter 12 - Crypto Officer and User Guide

Installation	12-1
Installing.....	12-1
Uninstalling	12-1
Commands	12-1
Initialization	12-1
De-initialization	12-1
Self-Tests.....	12-1
Show Status.....	12-1
When Module is Disabled	12-1

Chapter 13 - Customer Support

Introduction

Overview

This is a non-proprietary Federal Information Processing Standard (FIPS) 140-2 Security Policy for **Honeywell Scanning and Mobility FIPS Module Versions 4.0 B and 4.0 S** (Scanning and Mobility FIPS Module). The Scanning and Mobility FIPS Module is a cryptographic toolkit for C language users, providing services of various cryptographic algorithms such as hash algorithms, encryption schemes, message authentication, and public key cryptography. This Security Policy specifies the rules under which the Scanning and Mobility FIPS Module must operate. These security rules are derived from the requirements of FIPS 140-2 [1], and related documents [6,7,8].

Purpose

This Security Policy is created for the following purposes:

1. It is required for FIPS 140-2 validation.
2. To outline the Scanning and Mobility FIPS Module's conformance to FIPS 140-2 Level 1 Security Requirements.
3. To provide users with how to configure and operate the cryptographic module in order to comply with FIPS 140-2.

References

- [1] NIST Security Requirements For Cryptographic Modules, FIPS PUB 140-2, July 26, 2011.
- [2] NIST Security Requirements For Cryptographic Modules, Annex A: Approved Security Functions for FIPS PUB 140-2, August 12, 2011.
- [3] NIST Security Requirements For Cryptographic Modules, Annex B: Approved Protection Profiles for FIPS PUB 140-2, July 26, 2011.
- [4] NIST Security Requirements For Cryptographic Modules, Annex C: Approved Random Number Generators for FIPS PUB 140-2, July 26, 2011.
- [5] NIST Security Requirements For Cryptographic Modules, Annex D: Approved Key Establishment Techniques for FIPS PUB 140-2, July 26, 2011.
- [6] NIST Derived Test Requirements for FIPS 140-2, Draft, January 4, 2011.
- [7] NIST Implementation Guidance for FIPS PUB 140-2 and the Cryptographic Module Validation Program, July 15, 2011.
- [8] NIST Frequently Asked Questions for the Cryptographic Module Validation Program, December 4, 2007.

Change Notes

Revision	Date	Author	Description
0.1	20 10/08/03	A.Y.	Moved to Subversion
0.2	2010/08/03	A.Y.	Improved some descriptions.
0.3	2010/08/04	A.Y.	Added information on the new platforms.
0.4	20 10/08/13	A.Y.	Updated IP notices.
0.5	2011/08/05	A.Y.	Added clarification on binary compatibility.
0.6	2011/08/05	A.Y.	Editorial corrections.

The following are placed here by RCS upon check-in.

\$Log: FIPSMODULEHandHeldSecurityPolicy.tex,v \$

Revision 1.3.14.14 2008/02/18 05:39:19 ayamada

Corrections and clarifications based on the comments from CMVP.

Revision 1.3.14.13 2008/01/10 19:29:01 ayamada

Correction on the firmware cryptographic boundary.

Correction: Software -> Firmware.

Revision 1.3.14.12 2008/01/10 16:24:50 ayamada

Correction in Figure 3: Operating System -> Firmware Image

Additions to Table 3: Initialization and Deinitialization.

Additions to Tables 3 and 5: Zeroization (i.e., destruction).

Revision 1.3.14.11 2008/01/04 14:11:41 ayamada Added a table on keys and CSPs.

A typo fix as well.

Revision 1.3.14.10 2007/07/03 11:38:48 ayamada Correction on Figure 3.

Revision 1.3.14.9 2007/06/28 15:18:35 ayamada Editorial correction.

Revision 1.3.14.8 2007/06/28 14:52:07 ayamada Further clarification on network port.

Revision 1.3.14.7 2007/06/27 14:07:49 ayamada More correction.

Revision 1.3.14.6 2007/06/26 18:28:56 ayamada Some editorial corrections.

Revision 1.3.14.5 2007/06/26 12:45:58 ayamada

Added the algorithm certificate numbers for the Scanner.

Revision 1.3.14.4 2007/06/06 18:55:50 ayamada Added the module for the scanner.

Revision 1.3.14.3 2007/05/03 12:40:10 ayamada

Added further information on the hardware and firmware.

Revision 1.3.14.2 2007/05/02 19:11:20 ayamada Correction on the hardware descriptions.

Revision 1.3.14.1 2007/04/26 13:33:45 ayamada Brought in the latest version from the trunk.

Revision 1.10 2007/04/19 13:56:28 ayamada More accurate description of the hardware.

Revision 1.9 2007/04/19 13:27:59 ayamada Correction in the instruction in Appendix.

Revision 1.8 2007/04/19 13:23:22 ayamada Clarification in the Appendix and typo fix.

Revision 1.7 2007/04/09 16:06:22 ayamada Added more on the Operational Environment.

Revision 1.6 2007/04/09 15:18:59 ayamada Editorial correction.

Revision 1.5 2007/04/03 15:45:34 ayamada Correction on the HW diagram and description.

Revision 1.4 2007/04/03 14:59:27 ayamada Hardware and firmware information is added.

Cryptographic Module Specification

The Scanning and Mobility FIPS Module is a multiple-chip standalone firmware cryptographic module.

Physical Specifications

The Scanning and Mobility Module was tested on the Honeywell BASE 20205B/4820SF and Honeywell Xenon 1902 Cordless Base/Scanner.

Version 4.0 B Hardware

The hardware component of Honeywell Scanning & Mobility BASE 20205B-FIPSE or Honeywell Xenon 1902 Cordless BASE consists of the following devices:

1. CPU (ARM 920T or ARM 926EJ-S, respectively)
2. Memory
 - (a) Working memory is located on the RAM containing the following spaces:
 - i Input/output buffer
 - ii Plaintext/Ciphertext buffer
 - iii Control bufferKey storage is not deployed in this module.
 - (b) Program memory is also located on RAM.
3. LED
4. Serial Port
5. Wireless Network Interface
6. Power Supply

The configuration of this component is illustrated below.

Cryptographic Module 4.0 B Hardware Block Diagram

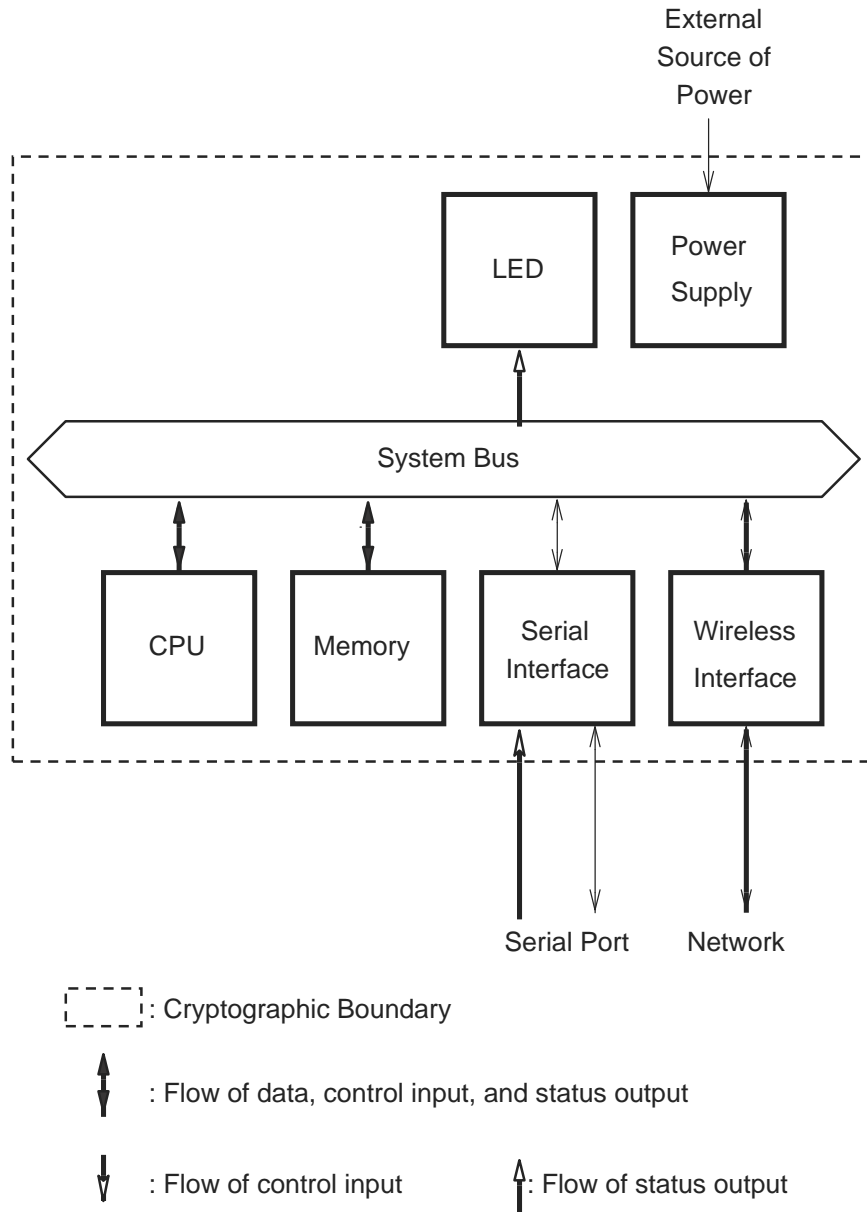

Version 4.0 S Hardware

The hardware component of Honeywell Scanning & Mobility Scanner 4820SF-FIPSE or Honeywell Xenon 1902 Cordless Scanner consists of the following devices:

1. CPU (ARM 920T or ARM 926EJ-S, respectively)
2. Memory
 - (a) Working memory is located on the RAM containing the following spaces:
 - i Input/output buffer
 - ii Plaintext/Ciphertext buffer
 - iii Control buffer

Key storage is not deployed in this module.

(b) Program memory is also located on RAM.

- 3. Scanner
- 4. Button
- 5. LED
- 6. Serial Port
- 7. Wireless Network Interface
- 8. Battery

The configuration of this component is illustrated below.

Cryptographic Module 4.0S Hardware Block Diagram

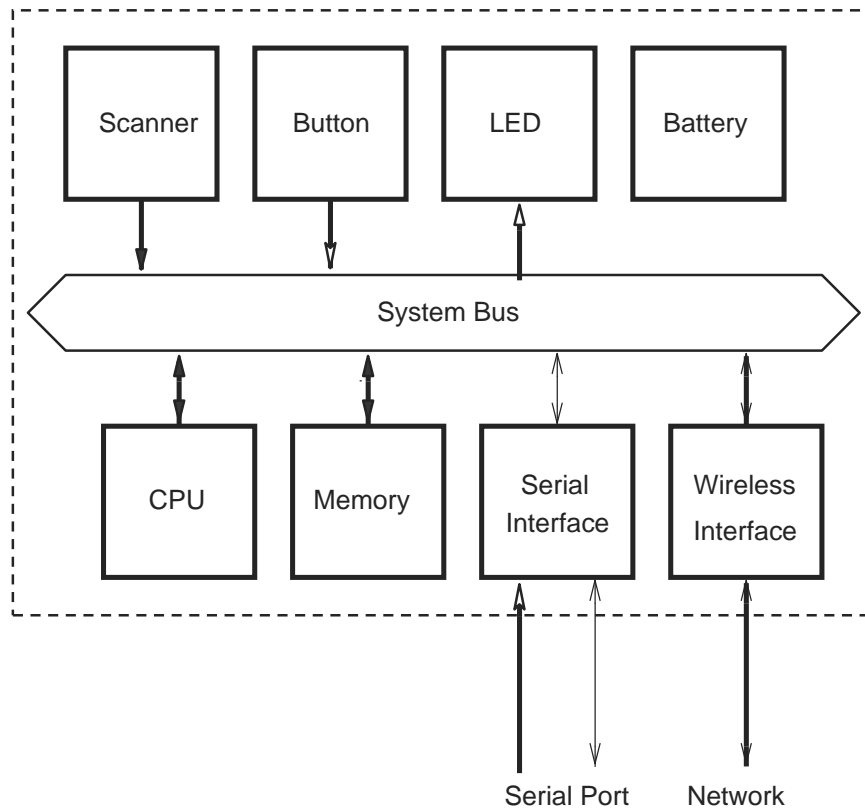

: Cryptographic Boundary

: Flow of data, control input, and status output

: Flow of control input

: Flow of status output

Firmware Specifications

The Scanning and Mobility FIPS Module is manufactured by Honeywell Scanning & Mobility, providing services to C computer language users.

The interface into the Scanning and Mobility FIPS Module is via Application Programmer's Interface (API) function calls. These function calls provide the interface to the cryptographic services, for which the parameters and return codes provide the control input and status output (see below).

Cryptographic Module Firmware Block Diagram

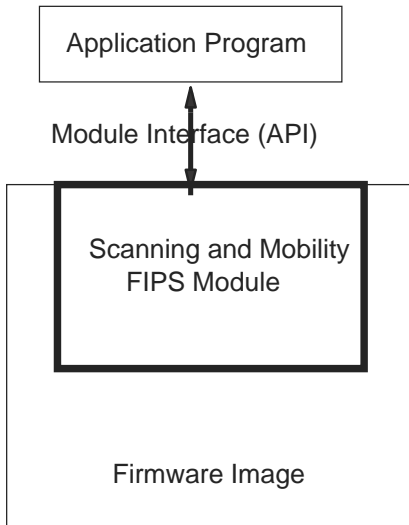

 : Cryptographic Boundary

 : Data flows

The Scanning and Mobility FIPS Module was tested with the firmware described in the following pages. The module can run on any other ARM devices with binary compatible firmware while maintaining its compliance to the FIPS 140-2 Level 1 requirements. In particular, the Scanning and Mobility FIPS module can be linked with the Honeywell Xenon 1902 Cordless Access Point Firmware that runs on the Honeywell Access Point (PN-AP-010-BT) in addition to the tested firmware below, and maintain vendor affirmed FIPS 140-2 compliance to the Level 1 requirements provided all of the conditions described in the Scanning and Mobility FIPS Module Versions 4.0 B and 4.0 S Security Policy are met.

Version 4.0 B Firmware

The Scanning and Mobility FIPS Module 4.0 B was linked with the Honeywell Scanning & Mobility BASE firmware 31205423-052 and Honeywell Xenon 1902 Cordless Base Firmware for testing.

Version 4.0 S Firmware

The Scanning and Mobility FIPS Module 4.0S was linked with Honeywell Scanning & Mobility Scanner firmware 31205480-025 and Honeywell Xenon 1902 Cordless Scanner firmware for testing.

Cryptographic Module Ports and Interfaces

Version 4.0 B Ports and Interfaces

The physical and logical interfaces for the Scanning and Mobility FIPS Module 4.0 B are summarized below.

Version 4.0 B Logical and Physical Interfaces

I/O	Logical Interface	Physical Interface
Data Input	API	Serial port
Data Output	API	Serial/Wireless port
Control Input	API	Serial Port
Status Output	Return Code	LED
Power Input	Initialization Function	The power supply is the power interface.
Maintenance	Not supported	Not supported

Version 4.0 S Ports and Interfaces

The physical and logical interfaces for the Scanning and Mobility FIPS Module 4.0 S are summarized below.

Version 4.0 S Logical and Physical Interfaces

I/O	Logical Interface	Physical Interface
Data Input	API	Scanner/Serial port
Data Output	API	Serial/Wireless port
Control Input	API	Button/Serial port
Status Output	Return Code	LED
Power Input	Initialization Function	N.A. (Battery is included.)
Maintenance	Not supported	Not supported



Roles, Services, and Authentication

Roles

The Scanning and Mobility FIPS Module supports Crypto Officer and User Roles. These roles are enforced by this Security Policy. The Crypto Officer has the responsibility for installing the Scanning and Mobility FIPS Module (see below).

Roles and Services

Service	Crypto Officer	User
Installation, etc.		
Installation	x	
Uninstallation	x	
Initialization	x	x
Deinitialization	x	x
Self-tests	x	x
Show status	x	x
Keys and CSPs Zeroization	x	x
Symmetric Cipher (AES)		
Key generation		x
Encrypt	x	x
Decrypt	x	x
Hash Algorithms and Message Authentication (SHA, HMAC)		
Hashing	x	x
Message Authentication	x	x
Random Number Generation (pRNG)		
Instantiation		x
Seeding	x	x
Request	x	x
Digital Signature (DSA)		
Key pair generation	x	x
Sign	x	x
Verify	x	x
Key Agreement (DH)		
Key pair generation	x	x
Shared secret generation	x	x

In order to operate the module securely, it is the Crypto Officer and User's responsibility to confine calls to those methods that have been FIPS 140-2 Approved or allowed. Thus, in the approved mode of operation, all Roles shall confine themselves to calling FIPS Approved or allowed algorithms, as marked in the following [Supported Algorithms and Standards](#) chart.

Services

The Scanning and Mobility FIPS Module supports many cryptographic algorithms. The following is the set of cryptographic algorithms supported by the Scanning and Mobility FIPS Module.

Supported Algorithms and Standards

	Algorithm	FIPS Approved or allowed	Cert. Number	
			4.0 B	4.0 S
Block Ciphers	AES (ECB, CBC, CFB 128, OFB 128,	x	#547	#590
Hash Functions	SHA-1 [FIPS 180-2]	x	#612	#641
	SHA-224 [FIPS 180-2]	x	#612	#641
	SHA-256 [FIPS 180-2]	x	#612	#641
Message Authentication	HMAC-SHA-1 [FIPS 198]		#288	#307
	HMAC-SHA-224 [FIPS 198]	x	#288	#307
	HMAC-SHA-256 [FIPS 198]		#288	#307
RNG	ANSI X9.62 RNG [ANSI X9.62]	x	#315	#336
Digital Signature	DSA [FIPS 186-2]		#222	#232
Key Agreement	DH [ANSI X9.42]			

The AES, SHA-1, SHA-224, SHA-256, HMAC-SHA-1, HMAC-SHA-224, HMAC-SHA256, RNG, and DSA algorithms have been validated to comply with FIPS. The Scanning and Mobility FIPS Module also supports a FIPS allowed key establishment technique (key agreement), Diffie-Hellman (DH). In order to operate the module in compliance with FIPS, only these FIPS Approved or allowed algorithms should be used.

The table below summarizes the keys and CSPs used in the FIPS mode.

Key and CSP, Key Size, Security Strength, and Access

Algorithm	Key and CSP	Key Size	Strength	Access
AES	key	128-256 bits	128-256 bits	Create, Read, Use, Destroy
HMAC	key	160-256 bits	80-128 bits	Create, Read, Use, Destroy
pRNG	seed key, seed	160 bits	80 bits	Use
DSA	key pair	1024-15360 bits	80-256 bits	Create, Read, Use, Destroy
DH	static/ephemeral key pair	1024-15360 bits	80-256 bits	Create, Read, Use, Destroy

Operator Authentication

The Scanning and Mobility FIPS Module does not deploy authentication mechanism. The roles of Crypto Officer and User are implicitly selected by the operator.

Finite State Model

The Finite State model contains the following states:

- Installed/Uninitialized
- Initialized
- Self-test
- Idle
- Crypto Officer/User
- Error

The following are the important features of the state transition:

1. When the module is installed by the Crypto Officer, the module is in the Installed/Uninitialized state.
2. When the initialization command is applied to the module, i.e., the module is loaded on the memory, turning to the Initialization state. Then, it transits to the Self-Test state automatically, running the Power-up Tests. While in the Self-Test state, the module prohibits all data output via the data output interface. On success the module enters Idle; on failure the module enters Error and the module is disabled. From the Error state the Crypto Officer may need to re-install to attempt correction.
3. From the Idle state (which is only entered if self-tests have succeeded), the module can transit to the Crypto Officer/User state when an API function is called.
4. When the API function has completed successfully, the state transits back to Idle.
5. If the Conditional Test (Continuous RNG Test or Pair-wise Consistency Test) fails, the state transits to Error and the module is disabled.
6. When On-demand Self-test is executed, the module enters the Self-Test state. On success the module enters Idle; on failure the module enters Error and the module is disabled.
7. When the de-initialization command is executed, the module goes back to the Installed/Uninitialized state.



Physical Security

The Scanning and Mobility FIPS Module operates on a device where a production grade enclosure is used.



Operational Environment

The Scanning and Mobility FIPS Module runs in the non-modifiable environment, where the device is a base station for a hand-held scanner.



Cryptographic Key Management

The Scanning and Mobility FIPS Module provides the underlying functions to support FIPS 140-2 Level 1 key management. The user will select FIPS Approved or allowed algorithms and will handle keys with appropriate care to build up a system that complies with FIPS 140-2. It is the Crypto Officer and User's responsibility to select FIPS 140-2 validated algorithms (see [Supported Algorithms and Standards](#) on page 4-2).

Key Generation

The Scanning and Mobility FIPS Module provides FIPS 140-2 compliant key generation. The underlying random number generation uses a FIPS Approved method, the ANSI X9.62 RNG (see reference [4] in [References](#) (page 1-1)).

Key Establishment

The Scanning and Mobility FIPS Module provides the following FIPS allowed key establishment technique (see reference [5] in [References](#) (page 1-1)):

Diffie-Hellman (DH)

The Diffie-Hellman (DH) key agreement technique implementation supports modulus sizes from 512 bits to 15360 bits that provides between 56 and 256 bits of security strength, where 1024 bits and above must be used to provide minimum of 80 bits of security.

It is the application's responsibility to ensure that the appropriate key establishment techniques are applied to the appropriate keys.

Key Entry and Output

Keys must be imported or exported from the cryptographic boundary in encrypted form using a FIPS Approved algorithm.

Key Storage

The Scanning and Mobility FIPS Module does not store keys.

Zeroization of Keys

The Scanning and Mobility FIPS Module functions zeroize all intermediate security sensitive material. Zeroization of keys and CSPs must be performed by calling the destroy functions of the objects when no longer needed; otherwise Scanning and Mobility Module will not be functional.



Power-up Tests

Tests upon Power-up

Self-tests are initiated automatically by the module at start-up. The following tests are applied:

Known Answer Tests (KATs):

KATs are performed on AES, SHS, HMAC-SHS, and RNG. For DSA, Pair-wise Consistency Test is used.

Firmware Integrity Test:

The firmware integrity test deploys HMAC-SHA-256 to verify the integrity of the module.

On-Demand Self-Tests

On-demand self tests may be invoked by the Cryptographic Officer or User by invoking the function, `sbg4_FIPS140RunTest()`, which is described in the [Crypto Officer and User Guide](#) beginning on page 12-1.

Conditional Tests

The Continuous RNG Test is executed on all RNG generated data, examining the first 160 bits of each requested random generation for repetition. This ensures that the RNG is not stuck at any constant value.

Also, upon each generation of a DSA key pair, the generated key pair is tested of their correctness by generating a signature and verifying the signature on a given message as a Pair-wise Consistency Test.

Failure of Self-Tests

Failure of the Self-tests places the cryptographic module in the Error state, wherein no cryptographic operations can be performed. It is a hard error, and re-loading, and possibly re-building as well, of the firmware image is necessary to attempt recovery.

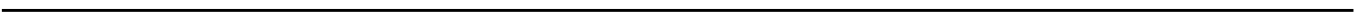

Configuration Management

A configuration management system for the cryptographic module is employed and has been described in a document to the testing laboratory. It uses the Concurrent Versioning System (CVS) to track the configurations.

Delivery and Operation

Refer to [Installation](#) on page 12-1 to review the steps necessary for the secure installation and initialization of the cryptographic module.

Development

Detailed design information and procedures have been described in documentation submitted to the testing laboratory. The source code is fully annotated with comments, and is also submitted to the testing laboratory.

Guidance Documents

The [Crypto Officer and User Guide](#) beginning on page 12-1 outlines the operations for the Crypto Officer and User to ensure the security of the module.

Mitigation of Other Attacks

Mitigation of Other Attacks

The Scanning and Mobility FIPS Module implements mitigation of an attack on biased private key of DSA.

Attack on Biased Private Key of DSA

The standards for choosing ephemeral values in DSA introduce a slight bias. Means to exploit these biases were presented to ANSI by D. Bleichenbacher.

In order to mitigate this attack, the following is executed: The bias in the RNG is reduced to levels which are far below the Bleichenbacher attack threshold. Change Notice 1 of FIPS 186-2 is published to mitigate this attack:

<http://csrc.nist.gov/CryptoToolkit/tkdigsigs.html>



Installation

In order to carry out a secure installation of the Scanning and Mobility FIPS Module, the Crypto Officer must follow the procedure described in this section.

Installing

The Crypto Officer is responsible for the installation of the Scanning and Mobility FIPS Module. Only the Crypto Officer is allowed to install the product.

Build the firmware image to be loaded by linking the object module, sbgse 4.0, to the application. Then load the image that includes the object module to the device.

Uninstalling

Overwrite the object module, sbgse4.0, on the device.

Commands

Initialization

`sbg4FIPS140Initialize ()`

This function runs a series of self-tests on the module. These tests examine the integrity of the shared object, and the correct operation of the cryptographic algorithms. If these tests are successful, a value of `SBSUCCESS` will be returned and the module will be enabled.

De-initialization

`sbg4FIPS140Deinitialize ()` This function de-initializes the module.

Self-Tests

`sbg4FIPS140RunTest ()`

This function runs a series of self-tests, and return `SBSUCCESS` if the tests are successful. These tests examine the integrity of the shared object, and the correct operation of the cryptographic algorithms. If these tests fail, the module will be disabled. [When Module is Disabled](#) (below) describes how to recover from the disabled state.

Show Status

`sbg4FIPS140GetState ()`

This function will return the current state of the module.

When Module is Disabled

When the Scanning and Mobility FIPS Module becomes disabled, attempt to bring the module back to the Installed state by calling `sbg4FIPS140Deinitialize()`, and then to initialize the module using `sbg4FIPS140Initialize()`. If the initialization is successful, the module is recovered. If this attempt fails, uninstall the module and re-install it. If the module is initialized successfully by this re-installation, the recovery is successful. If this recovery attempt fails, it indicates a fatal error. Contact [Customer Support](#) (see page 13-1) immediately.

Technical Assistance

If you need assistance installing or troubleshooting your device, please call your distributor or the nearest technical support office:

North America/Canada

Telephone: (800) 782-4263
E-mail: hsmnasupport@honeywell.com

Latin America

Telephone: (803) 835-8000
Telephone: (800) 782-4263
E-mail: hsmlasupport@honeywell.com

Brazil

Telephone: +55 (11) 5185-8222
Fax: +55 (11) 5185-8225
E-mail: brsuporte@honeywell.com

Mexico

Telephone: 01-800-HONEYWELL (01-800-466-3993)
E-mail: soporte.hsm@honeywell.com

Europe, Middle East, and Africa

Telephone: +31 (0) 40 7999 393
Fax: +31 (0) 40 2425 672
E-mail: hsmeurosupport@honeywell.com

Hong Kong

Telephone: +852-29536436
Fax: +852-2511-3557
E-mail: aptechsupport@honeywell.com

Singapore

Telephone: +65-6842-7155
Fax: +65-6842-7166
E-mail: aptechsupport@honeywell.com

China

Telephone: +86 800 828 2803
Fax: +86-512-6762-2560
E-mail: aptechsupport@honeywell.com

Japan

Telephone: +81-3-6730-7344
Fax: +81-3-6730-7222
E-mail: aptechsupport@honeywell.com

Online Technical Assistance

You can also access technical assistance online at www.honeywellaidc.com.



Honeywell Scanning & Mobility
9680 Old Bailes Road
Fort Mill, SC 29707

www.honeywellaidc.com